

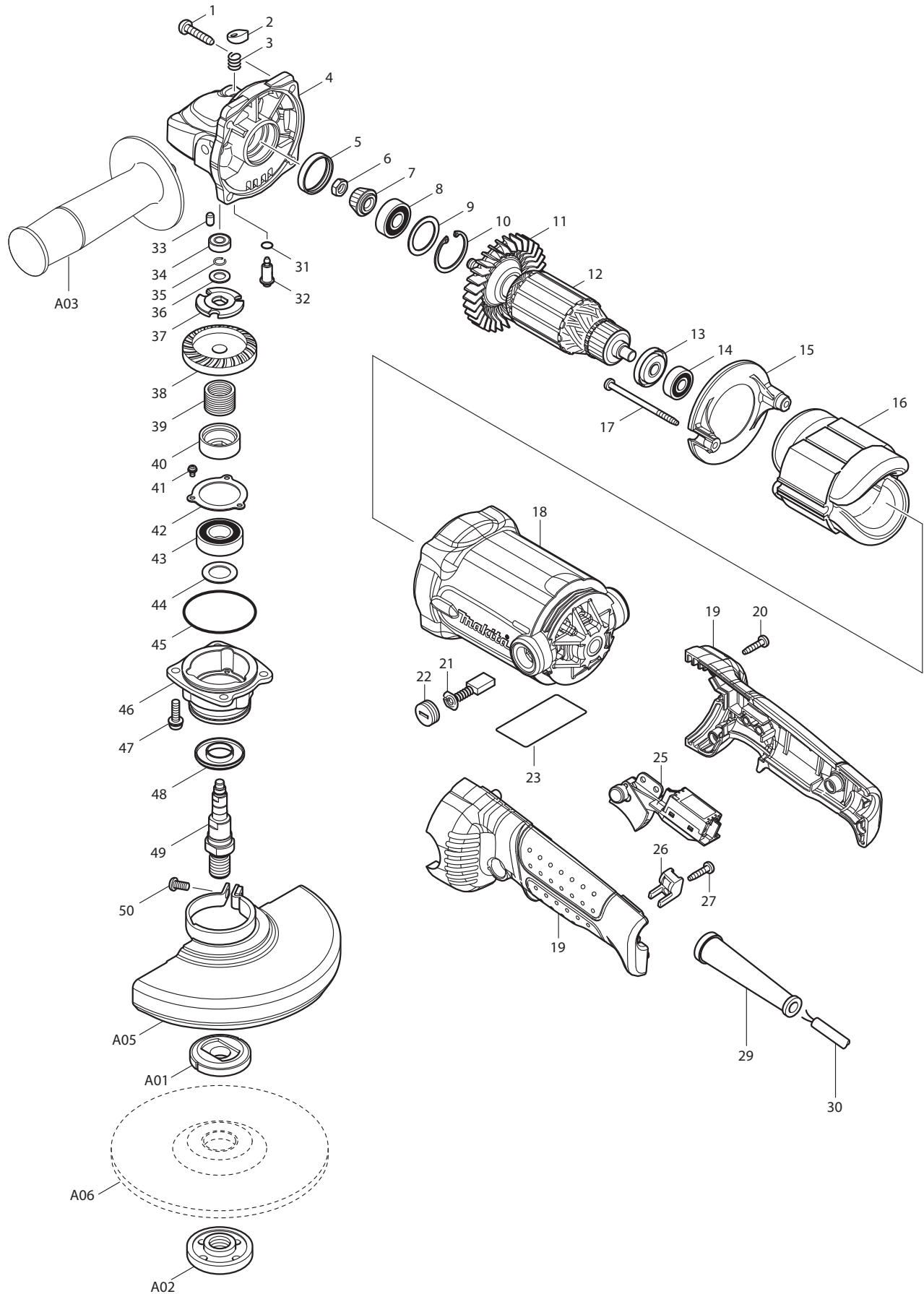

06 - 2010

GA6020

6" GRINDER, SJS, W/O LOCK



Item No	Type	Ref	Part No	Description	Qty	Unit
001	2		266459-3	TAPPING SCREW 5X25	4	PC.
002			417771-6	PIN CAP	1	PC.
003			234057-1	COMPRESSION SPRING 8	1	PC.
004			318158-4	GEAR HOUSING	1	PC.
005			262132-3	RUBBER RING 27	1	PC.
006			264010-3	HEX.NUT M7	1	PC.
007			227520-1	SPIRAL BEVEL GEAR 11	1	PC.
008	2		210059-1	BALL BEARING 6000DDW (Nylon)	1	PC.
009			267352-4	FLAT WASHER 22	1	PC.
010			962107-9	RETAINING RING (INT) R-30	1	PC.
011			240094-5	FAN 70	1	PC.
012			513706-6	ARMATURE ASS'Y 115V	1	PC.
		INC.		Item No. 11,13,14		
013			681644-1	INSULATION WASHER	1	PC.
014			210005-4	BALL BEARING 608DDW	1	PC.
015			419961-7	BAFFLE PLATE	1	PC.
016	2		520057-0	* FIELD ASS'Y 115V	1	PC.
		INC.	654020-2	* RING TERMINAL	1	PC.
		INC.	654555-3	* CONNECTOR 34130	1	PC.
017			266340-8	TAPPING SCREW 4X65	2	PC.
018	2		158364-7	MOTOR HOUSING COMPLETE	1	PC.
		INC.	643708-9	BRUSH HOLDER 5-11	2	PC.
		INC.	810341-4	CAUTION LABEL	1	PC.
		INC.	810323-6	CAUTION LABEL	1	PC.
019			188292-2	HANDLE SET	1	SET
020			266326-2	TAPPING SCREW 4X18	4	PC.
021	2		194998-2	CARBON BRUSH CB-311 2PC/SET (W/ ORIGIN)	1	SET
022			643750-0	BRUSH HOLDER CAP	2	PC.
023			863618-6	NAME PLATE F/GA6020	1	PC.
025			651195-8	SWITCH TG933TNB-1	1	PC.
026			687260-7	STRAIN RELIEF	1	PC.
027			266326-2	TAPPING SCREW 4X18	1	PC.
029			682505-8	CORD GUARD 10-90	1	PC.
030			664265-4	CORD WITH PLUG 2P-16-2.5M SJ	1	PC.
031			213977-2	O RING 7	1	PC.
032			256505-0	SHOULDER PIN 5	1	PC.
033			263002-9	RUBBER PIN 4	1	PC.
034			210006-2	BALL BEARING 696ZZ	1	PC.
035			233926-3	RING SPRING 7	1	PC.
036			253835-0	FLAT WASHER 8	1	PC.
037	2		267811-8	LOCK WASHER	1	PC.
038			227522-7	SPIRAL BEVEL GEAR 35B	1	PC.
039	2		234356-1	* LOCK SPRING 16	1	PC.
040			324833-2	LOCK SLEEVE	1	PC.
041			911003-8	PAN HEAD SCREW M3X6	3	PC.
042			285728-3	BEARING RETAINER 39	1	PC.
043	2		211236-8	BALL BEARING 6002DDW	1	PC.
044			253853-8	FLAT WASHER 15	1	PC.
045			213624-5	O RING 48	1	PC.
046	2		318299-6	* BEARING BOX	1	PC.
046	3		318332-4	* BEARING BOX	1	PC.
047			265131-4	PAN HEAD SCREW M5X18	4	PC.
048			345464-4	LABYRINTH RING	1	PC.
049			324790-4	SPINDLE A	1	PC.
050	1		265103-9	* PAN HEAD SCREW M5X14(F/165488-2)	1	PC.

Item No	Type	Ref	Part No	Description	Qty	Unit
			251391-4	* PAN HEAD SCREW M5X16(F/135172-3, 135110-5)	1	PC.
			265180-1	* PAN HEAD SCREW M5X16(F/123146-6)	1	PC.
D01			652044-2	(+) BIND SCREW M3.5 X 5.0	4	PC.
D02	1		654037-5	* INSULATED EYE TERMINAL FT1.25-M3	3	PC.
	2		654117-7	* INSULATING TERMINAL	3	PC.
D03			654077-3	INSULATED TERMINAL FV2-M3	2	PC.
E01			654532-5	TERMINAL BLOCK 1P	1	PC.
ACCESSORIES			- See catalogue or visit www.makita.ca for more optional accessories -			
A01			224361-6	INNER FLANGE 82	1	PC.
	Opt.		224390-9	INNER FLANGE 48 (FOR CUT-OFF)	1	PC.
A02			224568-4	LOCK NUT 5/8-45	1	PC.
	Opt.		224574-9	LOCK NUT 5/8-48 (FOR CUT-OFF)	1	PC.
A03	2		158237-4	GRIP 36 COMPLETE (RUBBER GRIP)	1	PC.
A04			782424-9	LOCK NUT WRENCH 28	1	PC.
A05	2		135172-3	* TOOLLESS WHEEL COVER ASSY F/6" (H:55MM)	1	PC.
		INC.		* Item No. 50		
	3		135110-5	* TOOLLESS WHEEL COVER ASSY F/6" (H:43.5MM)	1	PC.
		INC.		* Item No. 50		
	4		123146-6	* TOOLLESS WHEEL COVER ASSY F/6" (H:43.5MM)	1	PC.
		INC.		* Item No. 50		
		INC.	213009-5	* O RING 4 (Added)	1	PC.
	Opt.2		135192-7	* CONVENTIONAL WHEEL COVER ASSY 6"	1	PC.
		INC.	265180-1	* PH SCREW M5X16	1	PC.
A06	1		A-80846	6" DEPRESSED CENTER WHEEL GRIT 36	1	PC.
	2		D-29309	6" DEPRESSED CENTER WHEEL GRIT A24R	1	PC.
	2		A-95978-25	6" D.C.G.W WA36N 25/PK	1	SET
	Opt.		-----	DEPRESSED CENTER GRINDING WHEELS		
A08	2		194514-0	VIBRATION PROOF GRIP F/4" - 6", PKG	1	PC.
A09	2		193048-0	SANDING LOCK NUT 5/8-48	1	PC.
A10			743016-9	RUBBER PAD 125 F/6"	1	PC.
A11			194482-7	DUST COVER ATTACHMENT	1	PC.
A12			194483-5	LOOP HANDLE SET	1	SET
		INC.	416256-9	LOOP HANDLE	1	PC.
		INC.	450189-8	SPACER A	1	PC.
		INC.	450190-3	SPACER B	1	PC.
		INC.	783204-6	HEX WRENCH 6	1	PC.
		INC.	922453-2	HEX. SOCKET SCREW M8X30	2	PC.
A13	1		165486-6	CUT OFF WHEEL COVER F/6" (H:45MM) (Use with Screw #251391-4)	1	PC.
A18	2		165744-0	CUT OFF WHEEL COVER F/6" (H:50MM) (Use with Screw #251391-4)	1	PC.
A18	3		122912-8	CUT OFF WHEEL COVER F/6" (H:50MM) (Use with Screw #251391-4)	1	PC.

SERVICE CHANGES

1. Changes on Lock Spring

(TI#A5676)

Item No.	Description	Type 1	Type 2
39	Lock Spring 16	233957-2	234356-1

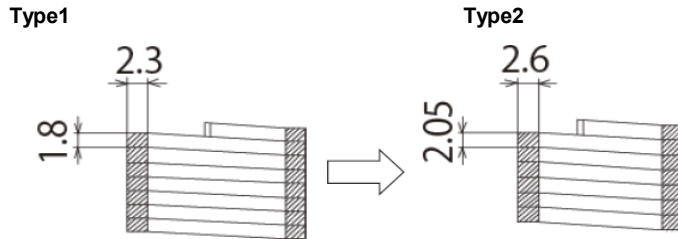

2. Changes on Filed Assy etc.

(TI#Z12397)

Item No.	Description	Type 1	Type 2
16	Field Ass'y 115V	525771-3	520057-0
	INC. Ring Terminal		654020-2
	INC. Connector P-1.25 > 34130	654501-6	654555-3
D02	Insulated Term. FK1.25-3M >Insulating Terminal	654037-5	654117-7

See Technical Information #Z12397 for Wiring Change Diagram

3. Changes on Wheel Cover Assembly & Bearing

(TI#80667, A4621)

(TI#B3256)

Item No.	Description	Type 2	Type3	Type 4
46	Bearing Box	318160-7	318299-6	318332-4
50	Pan Head Screw M5X16	251391-4		265180-1
A05	Toolless Wheel Cover Ass'y >Toolless Wheel Cover A125 Ass'y	135172-3	135110-5	123146-6
	INC. O ring 4	-----		213009-5
A05 Opt.	Conventional Wheel Cover Assy 6"	135169-2 or 135192-7		-----
A13 Opt.	Cut-Off Wheel Guard F/6"	165486-6 or 165744-0		122912-8

Item no. 50 is a component of A05

Type 3 > Type 4 parts above are interchangeable as a set

